

BLACKMER PARTS LIST

MODEL: STX3, STX3-DEF ¹

961822 **PARTS LIST**
Page 1 of 2 **203-A01**

Keep with Instructions 203-A00 for Installation, Operation and Maintenance

Section 203
Effective Dec 2013
Replaces June 2010

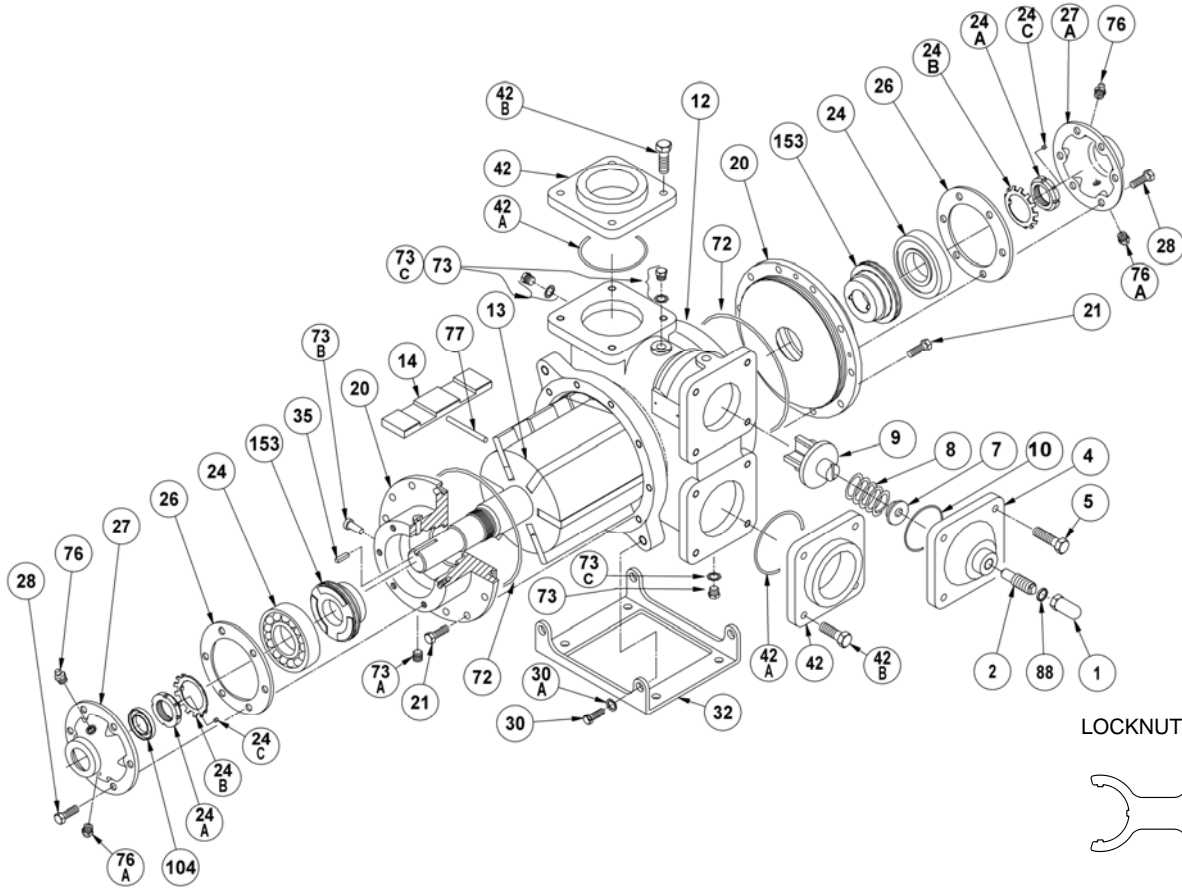

REF. NO.	DESCRIPTION	PARTS PER PUMP	PART NO.	REF. NO.	DESCRIPTION	PARTS PER PUMP	PART NO.
1	Cap – Relief Valve (R/V)	1	413151	30	Capscrew – Foot Bracket	4	924071
2	Adjusting Screw – R/V	1	433101	30A	Lockwasher – Bracket (12 mm STS)	4	909586
4	Cover – R/V	1	415301	32	Mounting Bracket	1	832225
5	Capscrew – R/V Cover	4	924036	35	Key – Shaft (10mm Metric)	1	909146
7	Spring Guide – R/V	1	423101		Key – Shaft (5/16" Domestic)		909206
8	Spring – R/V (51- 75 psi)	1	471632	42	Flange – 3" Weld	2	652201
	Spring – R/V (76 –110 psi)		471632	42A	O-Ring – Flange, PTFE	2	702101
	Spring – R/V (111-125 psi)		471615	42B	Capscrew – Flange	8	924071
9	Valve – R/V	1	455301	72	O-Ring – Head, PTFE	2	702210
10	O-Ring – R/V Cover, PTFE	1	702079	73	Plug – ¼" BSPP Hex Head	3	908201
12	Cylinder	1	022225	73A	Pipe Plug – ¼" NPT Socket Head	2	908192
13	Rotor & Shaft	1	262225	73B	Plug – Weep Hole	4	340000
14	Vane – Duravane	6	094500	73C	Gasket	3	533101
20	Head	2	032227	76	Grease Fitting	2	317815
21	Capscrew – Head	20	924036	76A	Grease Relief Fitting	2	701992
24	Bearing	2	903172	77	Push Rod	3	122225
24A	Locknut w/setscrew	2	903582	88	Seal Ring – R/V Cap, PTFE	1	533101
24B	Lockwasher	2	903524	104	Oil Seal	2	331908
24C	Setscrew – Locknut	2	924060	153	Mechanical Seal	2	332260
26	Gasket – Bearing Cover	2	381817	186	Shaft Protector	1	341801
27	Bearing Cover	0 – 1	042225		Tool – Locknut		903091
28	Capscrew – Bearing Cover	12	924031				

¹ STX3-DEF model requires special cleaning/testing. Consult factory if not familiar with these procedures.

MECHANICAL SEAL

REF. NO.	DESCRIPTION	PARTS PER PUMP	PART NO.
153	Mechanical Seal Complete – Silicon Carbide Stationary Seat, PTFE O-Ring, Custom Carbon Rotating Seal Face with PTFE Seal Ring (LACT)	2	332260
153D	O-Ring – Stationary (PTFE)	2	702080
153L	Seal Ring – PTFE	2	**

** 153L PTFE Seal Ring is not available as a separate part.

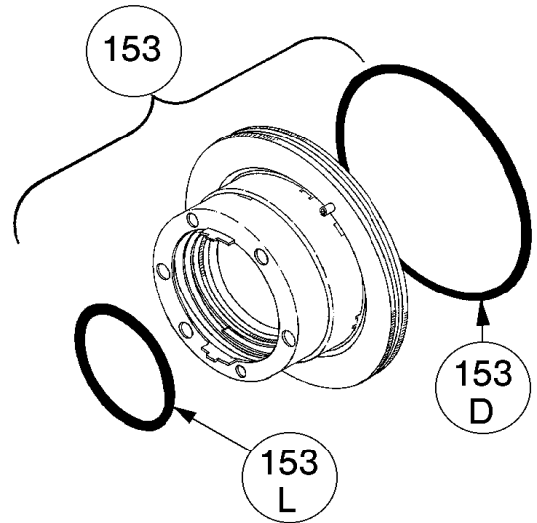

OPTIONAL HYDRAULIC MOTOR ADAPTER PARTS

REF. NO.	PART NAME	PARTS PER PUMP	PART NO.
---	Hydraulic Motor Adapter Kit *	See Below	892228
26A	Gasket – Hydraulic Motor Adapter	1	381817
28A	Capscrew – Hydraulic Motor Adapter / head	6	924037
34	Coupling w/ Setscrew – 1.25" straight key hyd. motor shaft	1	906969
35	Key – Coupling	1	909184
76	Grease Fitting	1	317815
76A	Grease Relief Fitting	1	701992
135	Hydraulic Motor Adapter – SAE A Flange	1	041829
135A	Capscrew – Adapter / Motor	2	920510

* Hydraulic Motor Adapter Kits shipped prior to Spring 2002 were of a two piece design – refer to page 206-A09.

