

BLACKMER PARTS LIST

PUMP MODEL: NP3F

Keep with Instructions 103-A00 for Installation, Operation and Maintenance

Section 103
Effective Aug 2011
Replaces June 2010

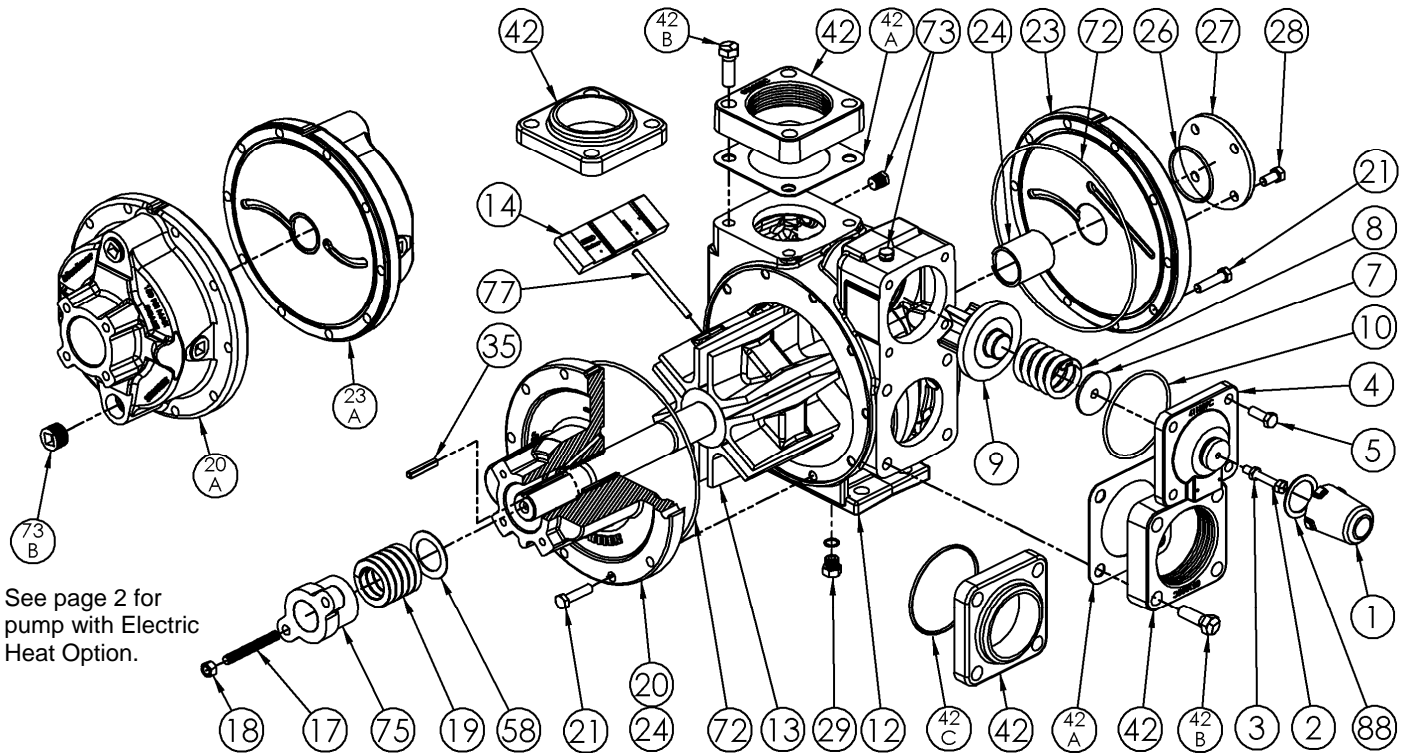

See page 2 for pump with Electric Heat Option.

Ref. No.	Description	Parts per Pump	Part No.	Ref. No.	Description	Parts per Pump	Part No.
1	Cap - Relief Valve (R/V)	1	413957	20	Head & Bushing Asy. - Inboard	1	031876
2	Adjusting Screw - R/V	1	431808	20A	Head & Bushing Asy. - Inboard (Jacket)	1	031866
3	Locknut - Adjusting Screw	1	922923	21	Capscrews - Head	20	920369
4	Cover - R/V (Std.)	1	411811	23	Head & Bushing Asy. - Outboard	1	031877
	Cover - R/V ^{1,6} (high pressure)		411868	23A	Head & Bushing Asy. - Outboard (Jacket)	1	031873
5	Capscrew - R/V Cover (Std.)	4	920331	24	Bushing (Sleeve Bearing)	2	⁴ 161600
	Capscrew - R/V Cvr ^{1,6} (high press.)		920381	26	O-Ring - Bearing Cover (FKM) (Std.)	1	⁴ 702038
7	Spring Guide - R/V	1	421805		O-Ring - Bearing Cover (PTFE)		702234
8	Spring - R/V (36-50 psi)	1	471805		O-Ring - Bearing Cover (Buna-N) ⁶		702037
	Spring - R/V (51-110 psi)		471806	27	Bearing Cover	1	041600
	Spring - R/V (111-150 psi)		471809	28	Capscrews - Bearing Cover	4	920291
	SS Spring - R/V (51-110 psi)		471807	29	Pipe Plug Asy. (SAE # 6) (FKM) (Std.)	1	908212
	SS Spring - R/V (111-150 psi)		471808		Pipe Plug Asy. (SAE # 6) (PTFE)		908213
	SS Spring - R/V (151-200 psi) ^{1,6}		471870		Pipe Plug Asy. (SAE #6) (Buna-N) ⁶		908211
9	Valve - R/V (Std.)	1	451807	35	Key - Shaft	1	⁴ 909177
	Valve - R/V (Nickel Plated) ⁶		451808	42	See page 4 for Flange Options		
10	O-Ring - R/V Cover (FKM) (Std.)	1	⁴ 711931	72	O-Ring - Head (FKM) (Std.)	2	⁴ 702232
	O-Ring - R/V Cover (PTFE)		702080		O-Ring - Head (PTFE)		702233
	O-Ring - R/V Cover (Buna-N) ⁶		701936		O-Ring - Head (Buna-N) ⁶		702231
12	Cylinder (Std.)	1	021805	73	Gage Plug	2	908198
	Cylinder w/ SAE Drain (Cast Iron) ⁶		021816	73B	Jacket Plug	0 - 4	908223
13	Rotor & Shaft, Open Rotor (Shown)	1	261868	77	Push Rods	3	⁴ 121807
	Rotor & Shaft, Closed Rotor (Opt.)		261880	88	Gasket - R/V Cap	1	^{4,5} 533909
14	Vane - Duravane (Std.) ⁶	6	⁴ 091819	—	Kit - Maintenance	—	898931
	Vane - EC Laminate		091829		EC = Extra Clearance		
	Vane - EC Cast Iron		091821		SS = Stainless Steel		
	Vane - EC Bronze		091804		⁴ Included in Maintenance Kit		

¹ High Pressure Relief Valve parts must be used as a group (includes p/n's 411868, 920381, and 471870) (ref 4, 5 & 8).

⁵ R/V Caps on earlier pumps used an O-ring; the 533909 Gasket may be used with the O-Ring type R/V Caps..

⁶ AFFF service pumps include: Nickel Pltd. High Press. RV, 200 psi RV spring, Buna O-rings, Cyl. w/ Drain, Lip Seal & Duravanes.

Pumps with Heads for Electric Heating

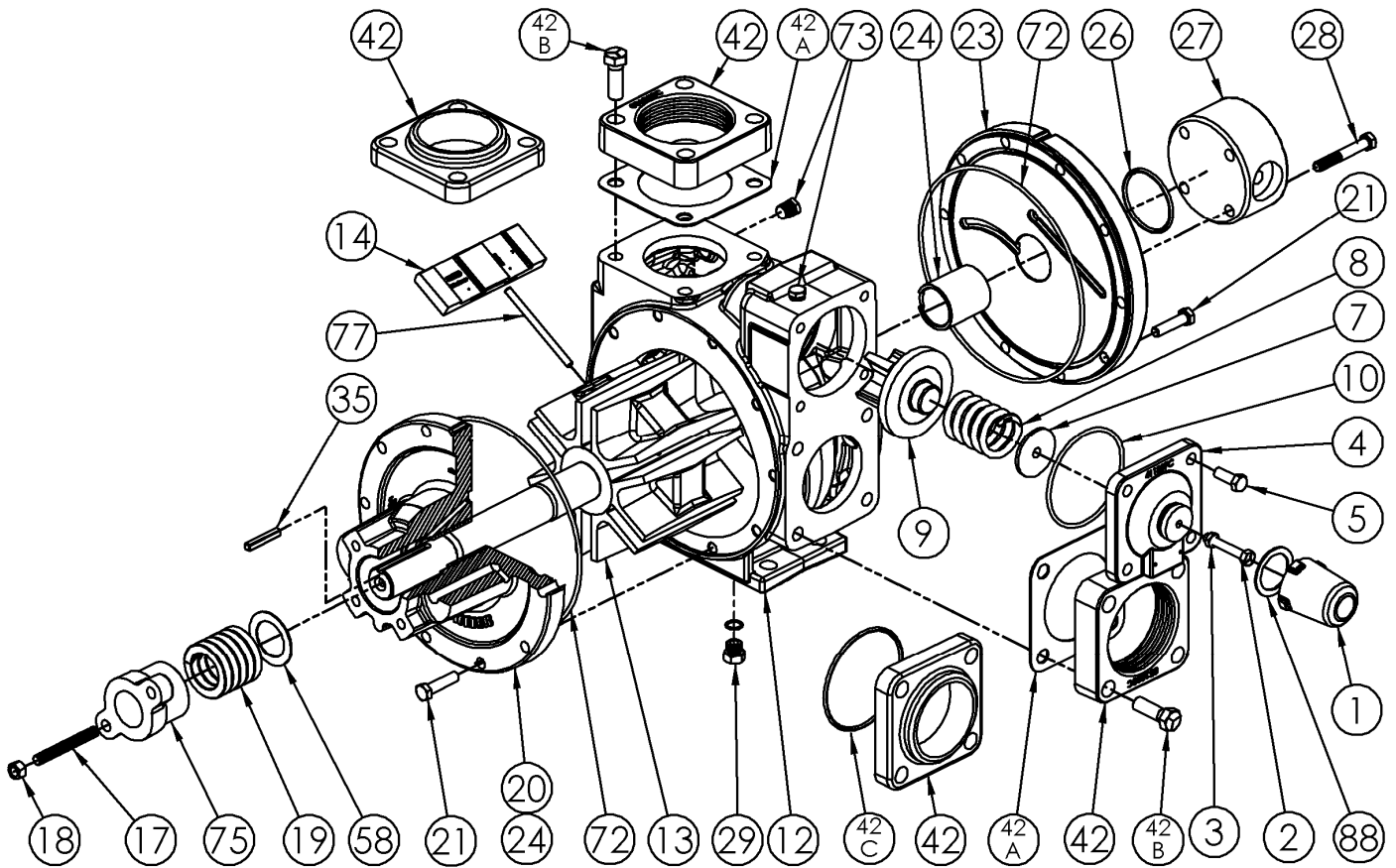

Ref. No.	Description	Parts per Pump	Part No.	Ref. No.	Description	Parts per Pump	Part No.
1	Cap - Relief Valve (R/V)	1	413957	20	Head & Bushing Assy. - Inboard EH	1	031886
2	Adjusting Screw - R/V	1	431808	21	Capscrews - Head	20	920369
3	Locknut - Adjusting Screw	1	922923	23	Head & Bushing Assy. - Outboard EH	1	031887
4	Cover - R/V (Std.)	1	411811	24	Bushing EH (Sleeve Bearing)	2	161601
5	Capscrew - R/V Cover (Std.)	4	920331	26	O-Ring - Bearing Cover (FKM) (Std.)	1	702038
7	Spring Guide - R/V	1	421805		O-Ring - Bearing Cover (PTFE)		702234
8	SS Spring - R/V (51-110 psi)	1	471807	27	Bearing Cover EH	1	041880
9	Valve - R/V (Std.)	1	451807	28	Capscrews - Bearing Cover EH	4	920444
	Valve - R/V (Nickel Plated)		451808	29	Pipe Plug Assy. (SAE # 6) (FKM) (Std.)	1	908212
10	O-Ring - R/V Cover (FKM) (Std.)	1	711931		Pipe Plug Assy. (SAE # 6) (PTFE)		908213
	O-Ring - R/V Cover (PTFE)		702080	35	Key - Shaft	1	909177
12	Cylinder (Std.)	1	021805	42	See page 4 for Flange Options		
	Cylinder w/ SAE Drain (Cast Iron)		021816	72	O-Ring - Head (FKM) (Std.)	2	702232
13	Rotor & Shaft, Open Rotor (Shown)	1	261868		O-Ring - Head (PTFE)		702233
	Rotor & Shaft, Closed Rotor (Opt.)		261880	73	Gage Plug	2	908198
14	Vane - Duravane (Std.)	6	091819	77	Push Rods	3	121807
	Vane - EC Laminate		091829	88	Gasket - R/V Cap	1	⁵ 533909
	Vane - EC Cast Iron		091821				
	Vane - EC Bronze		091804				

EH = Electric Heat Option EC = Extra Clearance SS = Stainless Steel

⁵ R/V Caps on earlier pumps used an O-ring; the 533909 Gasket may be used with the O-Ring type R/V Caps..



1809 Century Avenue, Grand Rapids, Michigan 49503-1530, U.S.A.
 Telephone: (616) 241-1611 / Fax: (616) 241-3752
 E-Mail: blackmer@blackmer.com / Internet: www.blackmer.com

Parts List 103-A04
 Page 2 of 4

PACKING - STANDARD & ELECTRIC HEAT OPTION

Ref. No.	Part Name	Parts Per Pump	Part No.
17	Stud - Packing Follower	2	921868
18	Nut - Packing Follower Stud	2	922428
19	Packing Set	1	⁴ 321868
	Packing Set – Electric Heat Option		321880
58	Pack Washer	1	355168
75	Packing Follower	1	141868

⁴ Included in Maintenance Kit

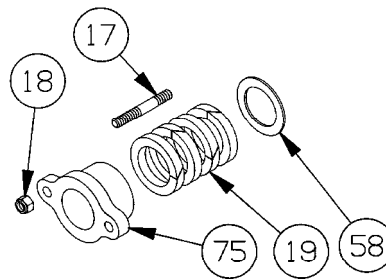

LIP SEAL - OPTIONAL ⁶

Ref. No.	Part Name	Parts Per Pump	Part No.
16	Capscrew - Follower	2	920359
75	Seal Follower	1	141868
152	Lip Seal Assembly (To 500°F)	1	702245
152D	Wave Spring	1	321601

NOTE: A Commercial Mechanical Seal (cartridge type) may be used in place of packing or lip seals. Consult mechanical seal manufacturer for more information.

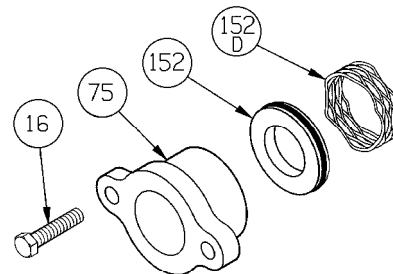

COMMERCIAL MECHANICAL SEAL (Cartridge Type) - OPTIONAL

Ref. No.	Part Name	Parts Per Pump	Part No.
-	John Crane 5610	1	331639

NOTE: Seal Materials (Sil-Car, Carbon, FKM)

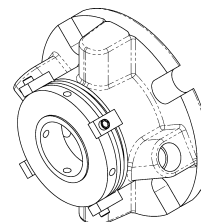

Commercial Mechanical Seal Cartridge Type

TRIPLE-LIP CARTRIDGE SEAL - OPTIONAL

Ref. No.	Part Name	Seal	Seal Rebuild Kit
—	TRIPLE-LIP CARTRIDGE SEAL	331774	899105
220	Shaft Sleeve O-Ring	2	X
221	Shaft Sleeve	1	
222	Gasket	1	X
223	Gland Plate Assembly	1	
224	Element O-Ring	1	X
225	Seal Spacer	1	X
226	Seal Element	3	X
227	Flushing Spacer	1	X
228	Flushing Spacer O-Ring	1	X
229	Retaining Ring	1	
230	Snap Ring	1	X
231	Shaft Sleeve Setscrews	6	X
233	Gland Capscrew	4	
234	Flat Washer	4	

X = Parts Included in Seal Rebuild Kit

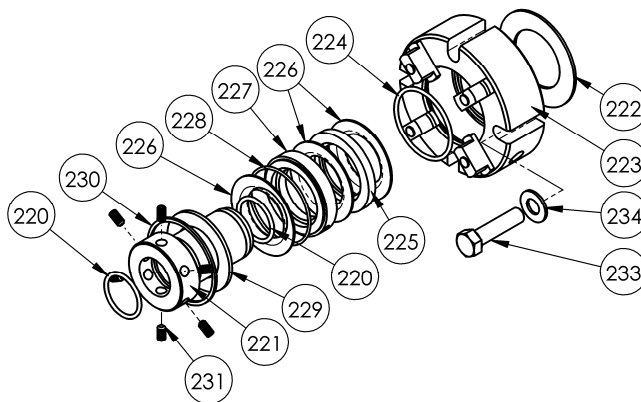

FLANGE OPTIONS

Ref. No.	Part Name	Parts Per Pump	Part No.
42	Flange - 3" NPT (Std.)	2	651803
	Flange - 3" Weld		655102
	Flange - ANSI 3" 150 lb. R.F.	0 - 2	651817
42A	Gasket - NPT Flange (Comp.) (Std.)	2	⁴ 381816
42B	Capscrew - (NPT Flange ONLY)	8	920532
	Capscrew - Weld / ANSI Flange		920510
42C	O-Ring - Flange (FKM)	0 - 2	701968
	O-Ring - Flange (PTFE)		702101
	O-Ring -Flange (Buna-N) ⁶		701937

