

TYPE	SIZE	UNIT STYLE
NP	4F	PO

DIMENSIONS 103-111	
Section	100
Effective	November 2001
Replaces	April 1993
Page 1/3	

RIGHT HAND ROTATION. FOR LEFT HAND ROTATION, SHAFT PROJECTION IS OPPOSITE THAT SHOWN.

\* TOLERANCE  $\pm \frac{1}{8}$

TOLERANCE ON OTHER DIMENSIONS  $\pm \frac{1}{4}$

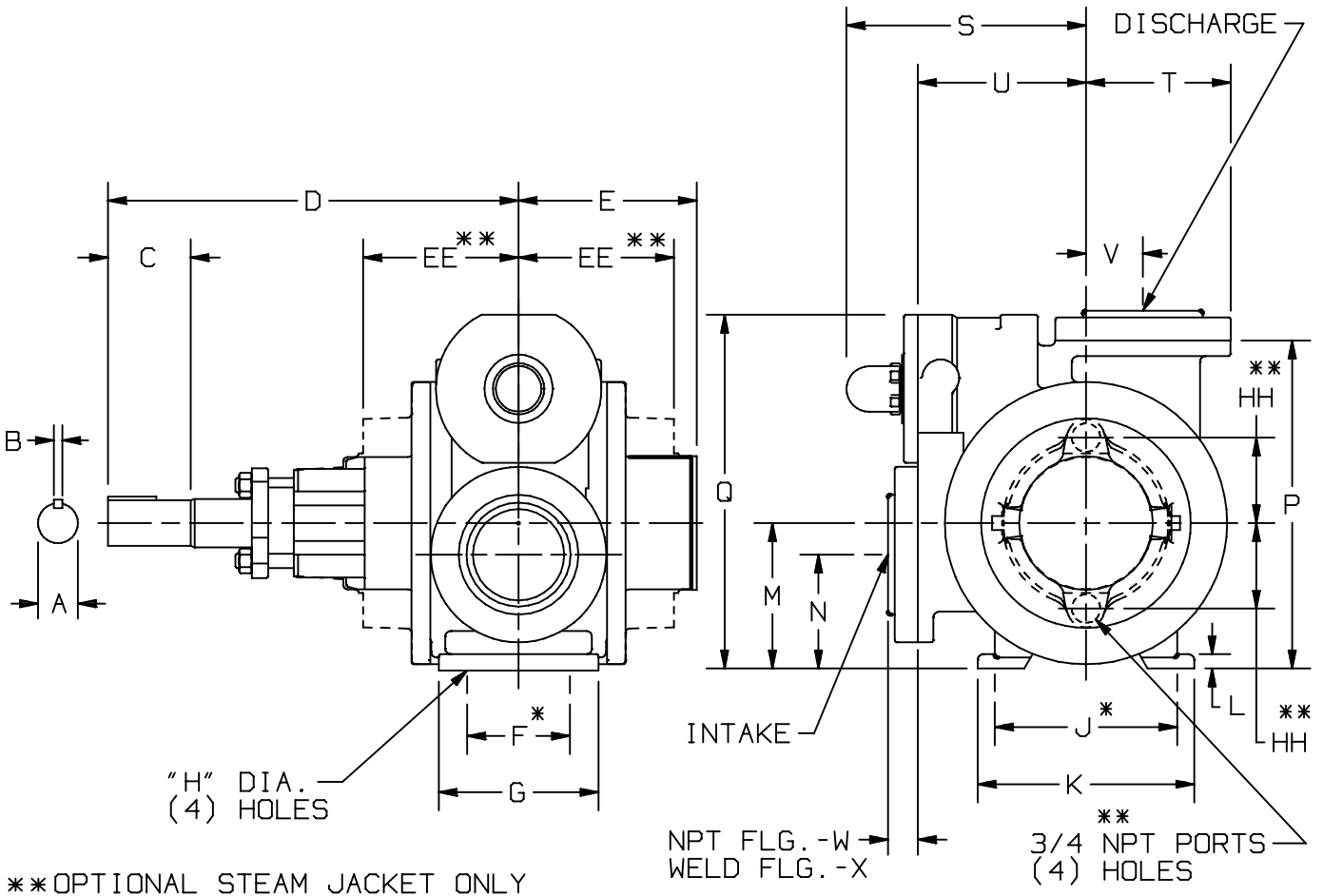

\*\*OPTIONAL STEAM JACKET ONLY

MOTOR			DIMENSIONS									
FRAME SIZE		UNITS	A	B	C	D	E	F	G	H	J	K
		IN	2	1/2	3 5/8	18	8 1/8	4 1/2	7	5/8	8	9 1/2
		MM	50,8	12,7	92,1	457,2	206,4	114,3	177,8	15,9	203,2	241,3
			L	M	N	P	Q	R	S	T	U	V
		IN	5/8	6 3/8	5	14 3/8	15 1/2	—	10 9/16	6 3/8	7 3/8	2 1/2
		MM	15,9	161,9	127	365,1	393,7	—	268,3	161,9	187,3	63,5
			W	X	Y	Z	AA	BB	CC	DD	EE	FF
		IN	1 5/16	3	—	—	—	—	—	19 1/2	6 7/8	—
		MM	33,3	76,2	—	—	—	—	—	495,3	174,6	—
			GG	HH					PUMP WEIGHT	WITH STD. FLANGES	** WITH JACKETED HEADS	
		IN	—	3 3/4					LBS	314	323	
		MM	—	95,2					KG	143	146,5	

NOTE: FOR ANSI AND DIN FLANGE DIMENSIONS, SEE DIMENSION SHEET 103-115

TYPE	SIZE	UNIT STYLE
NP	4	HRB

DIMENSIONS 103-111	
Section	100
Effective	November 2005
Replaces	November 2001
Page 2/3	

RIGHT HAND ROTATION SHOWN.

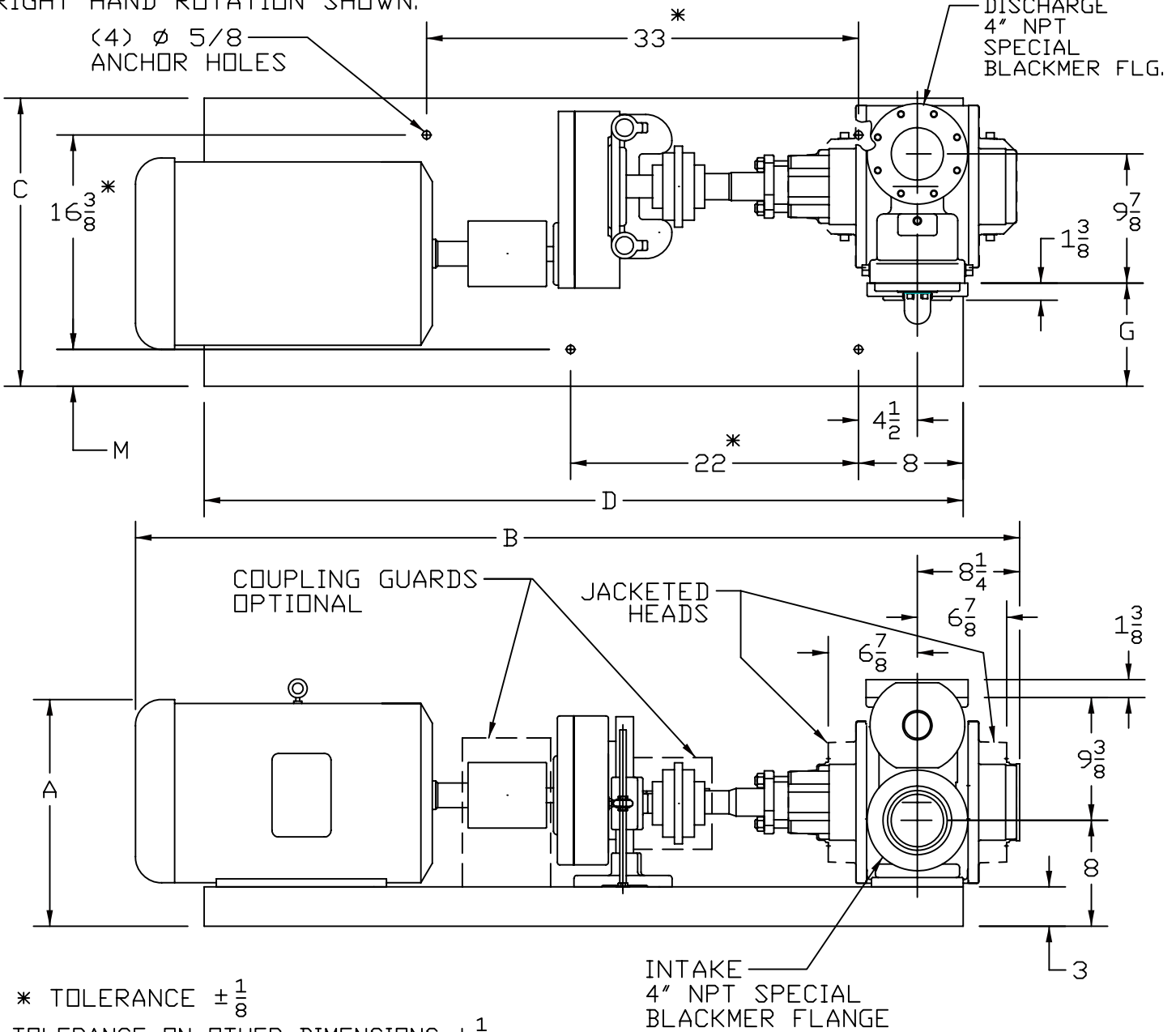

\* TOLERANCE  $\pm \frac{1}{8}$   
 TOLERANCE ON OTHER DIMENSIONS  $\pm \frac{1}{4}$   
 "A" DIMENSION LESS EYEBOLT

FRAME SIZE	MOTOR		BASE NO.	DIMENSIONS						APPROX. UNIT WT - POUNDS		
	H.P.	RPM		A	B	C	D	G	M	LESS MOTOR	ENCL MOTOR	
213T	7 1/2	1800	901661	14 1/8	58 1/4	20 3/8	50 1/2	4 1/4	2		570	725
215T	10	1800	901661	14 1/8	59 3/4	20 3/8	50 1/2	4 1/4	2		570	725
254T	15	1800	901662	16 1/8	63 1/4	22	58	5 1/16	2 13/16		645	880
256T	20	1800	901662	16 1/8	65 1/8	22	58	5 1/16	2 13/16		645	905
284T	25	1800	901663	17 5/8	67 1/8	22	58	5 1/16	2 13/16		645	1010
286T	30	1800	901663	17 5/8	68 5/8	22	58	5 1/16	2 13/16		645	1030
324T	30/25	1800/1200	901499	19 1/2	69 1/4	24	65	5 7/16	2		690	1170

**DIMENSIONS 103-111**

Section 100  
 Effective November 2005  
 Replaces November 2001  
 Page 3/3

TYPE

SIZE

UNIT  
STYLE

NP

4

HRB



www.blackmer.com

LEFT HAND ROTATION SHOWN.

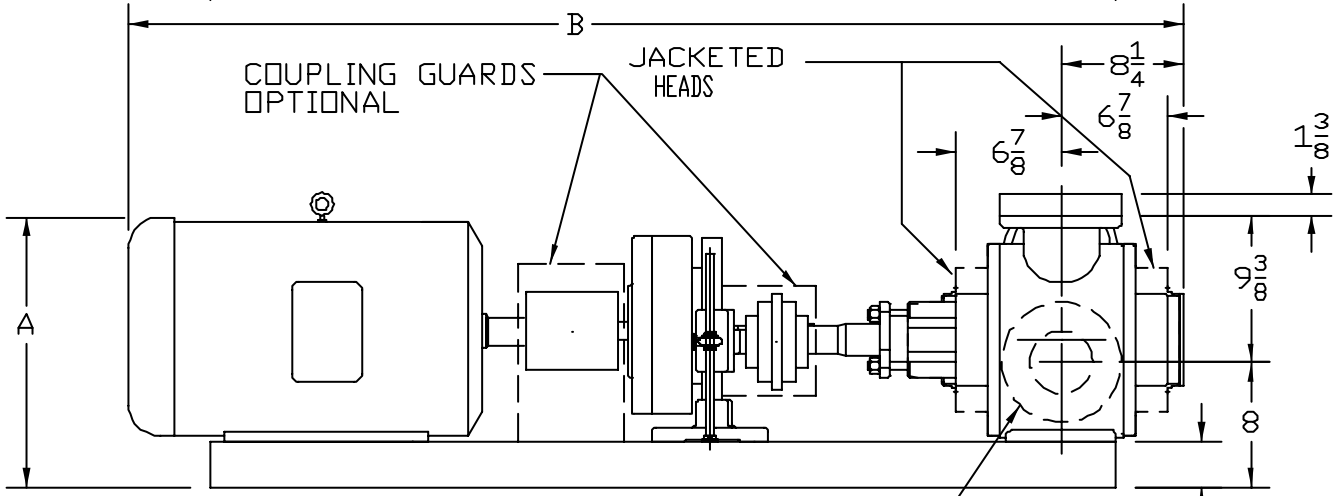
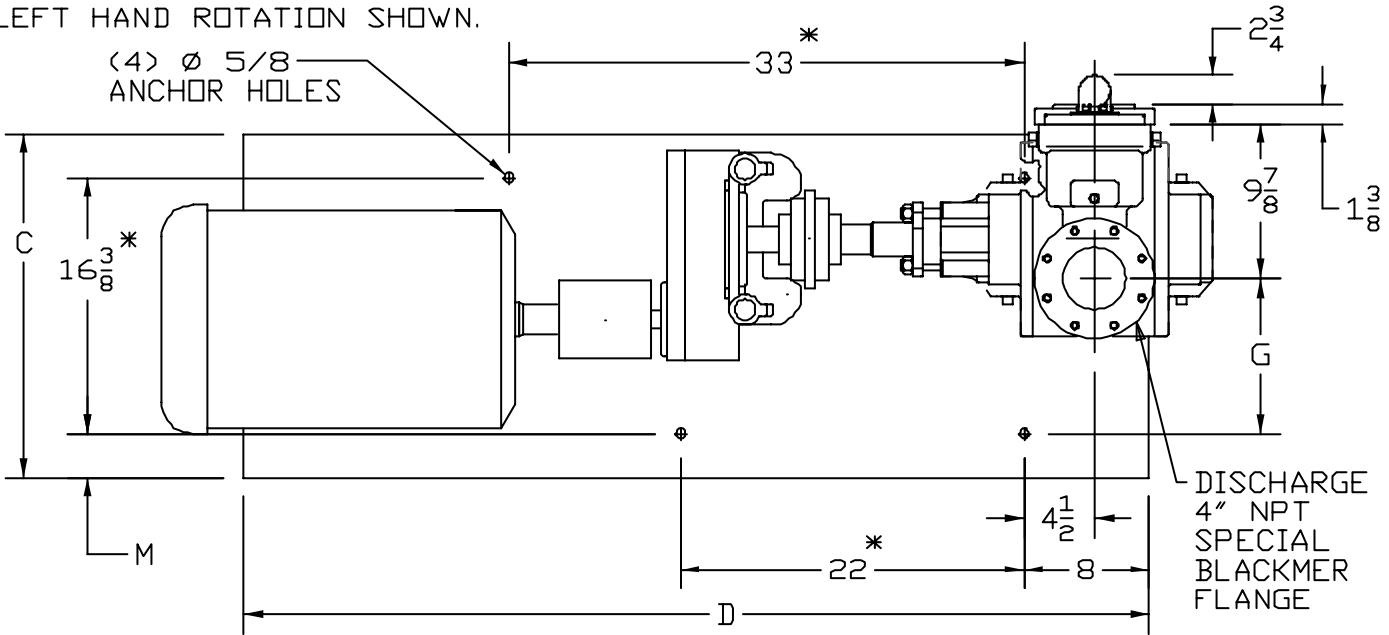

\* TOLERANCE  $\pm \frac{1}{8}$

TOLERANCE ON OTHER DIMENSIONS  $\pm \frac{1}{4}$

"A" DIMENSION LESS EYEBOLT

FRAME SIZE	MOTOR		BASE NO.	DIMENSIONS						APPROX. UNIT WT - POUNDS	
	H.P.	RPM		A	B	C	D	G	M	LESS MOTOR	ENCL MOTOR
213T	7 1/2	1800	901661	14 1/8	58 1/4	20 3/8	50 1/2	4 1/4	2	570	725
215T	10	1800	901661	14 1/8	59 3/4	20 3/8	50 1/2	9 1/8	2	570	725
254T	15	1800	901662	16 1/8	63 1/4	22	58	9 15/16	2 13/16	645	880
256T	20	1800	901662	16 1/8	65 1/8	22	58	9 15/16	2 13/16	645	905
284T	25	1800	901663	17 5/8	67 1/8	22	58	9 15/16	2 13/16	645	1010
286T	30	1800	901663	17 5/8	68 5/8	22	58	9 15/16	2 13/16	645	1030
324T	30/25	1800/1200	901499	19 1/2	69 1/4	24	65	10 5/16	2	690	1170