

TYPE	SIZE	UNIT STYLE
NP	1.5B	HRA

DIMENSIONS 103-103	
Section Effective	100 November 2001
Replaces	October 2000
Page 2/3	

RIGHT HAND ROTATION

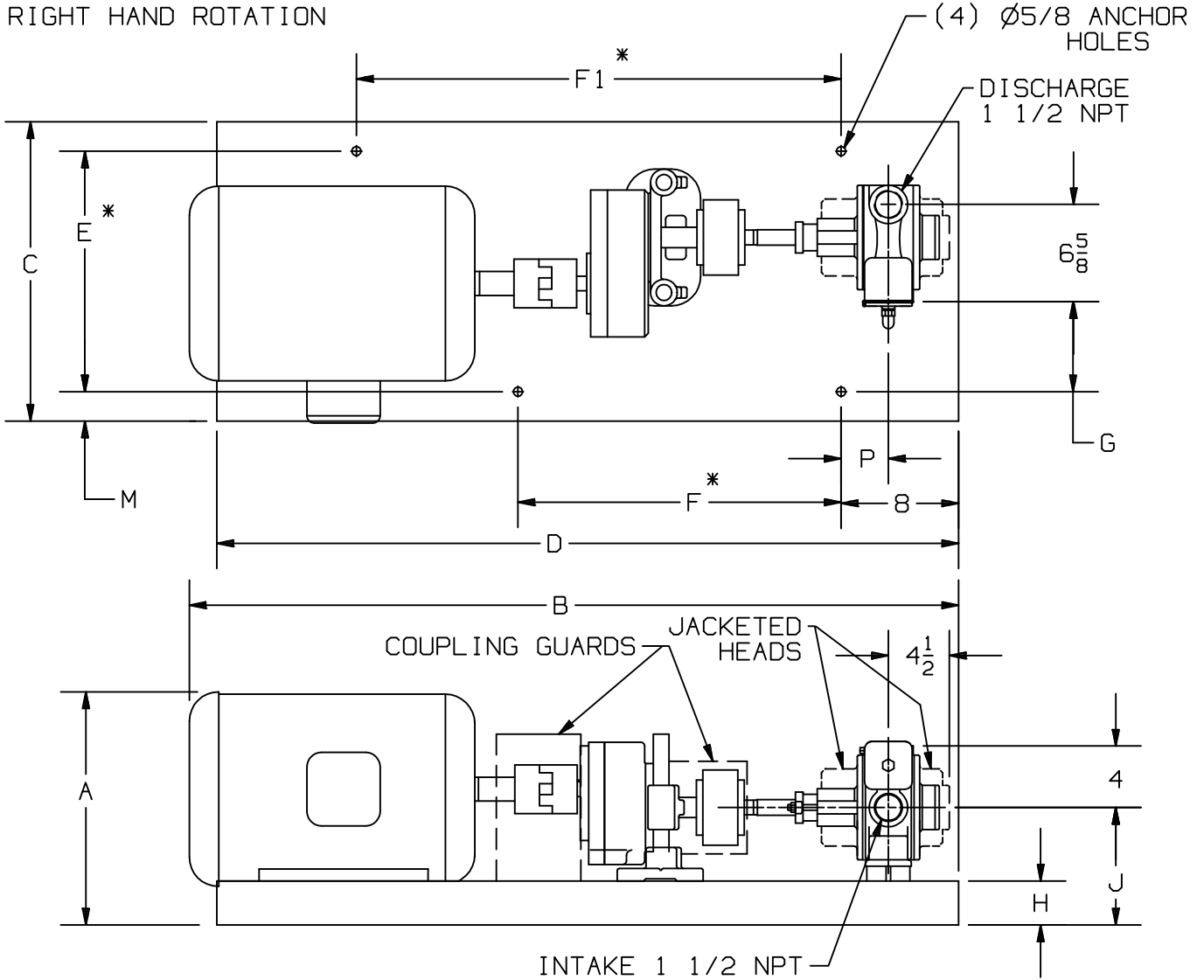

* TOLERANCE ±1/8
 TOLERANCE ON OTHER DIMENSIONS ±1/4
 "A" DIMENSION LESS EYEBOLT

MOTOR			BASE NO.	DIMENSIONS														
FRAME SIZE				A	B	C	D	E	F	F ₁	G	H	J	M	P			
143T			901795	9 3/4	45 3/8	17 1/4	44	14	15	26	5	2 1/4	7 1/4	1 5/8	4 1/8			
145T			901795	9 3/4	45 3/8	17 1/4	44	14	15	26	5	2 1/4	7 1/4	1 5/8	4 1/8			
182T			901795	11 7/8	45 3/8	17 1/4	44	14	15	26	5	2 1/4	7 1/4	1 5/8	4 1/8			
184T			901795	11 7/8	46 1/8	17 1/4	44	14	15	26	5	2 1/4	7 1/4	1 5/8	4 1/8			
213T			901794	14 1/8	51 1/4	20 3/8	50 1/2	16 3/8	22	33	6 1/8	3	8	2	3 1/4			
215T			901794	14 1/8	51 1/4	20 3/8	50 1/2	16 3/8	22	33	6 1/8	3	8	2	3 1/4			
254T			901794	16 3/8	53 1/8	20 3/8	50 1/2	16 3/8	22	33	6 1/8	3	8	2	3 1/4			
256T			901794	16 3/8	54 7/8	20 3/8	50 1/2	16 3/8	22	33	6 1/8	3	8	2	3 1/4			

DIMENSIONS 103-103

Section 100
 Effective November 2001
 Replaces October 2000
 Page 3/3

TYPE	SIZE	UNIT STYLE
NP	1.5B	HRA



LEFT HAND ROTATION

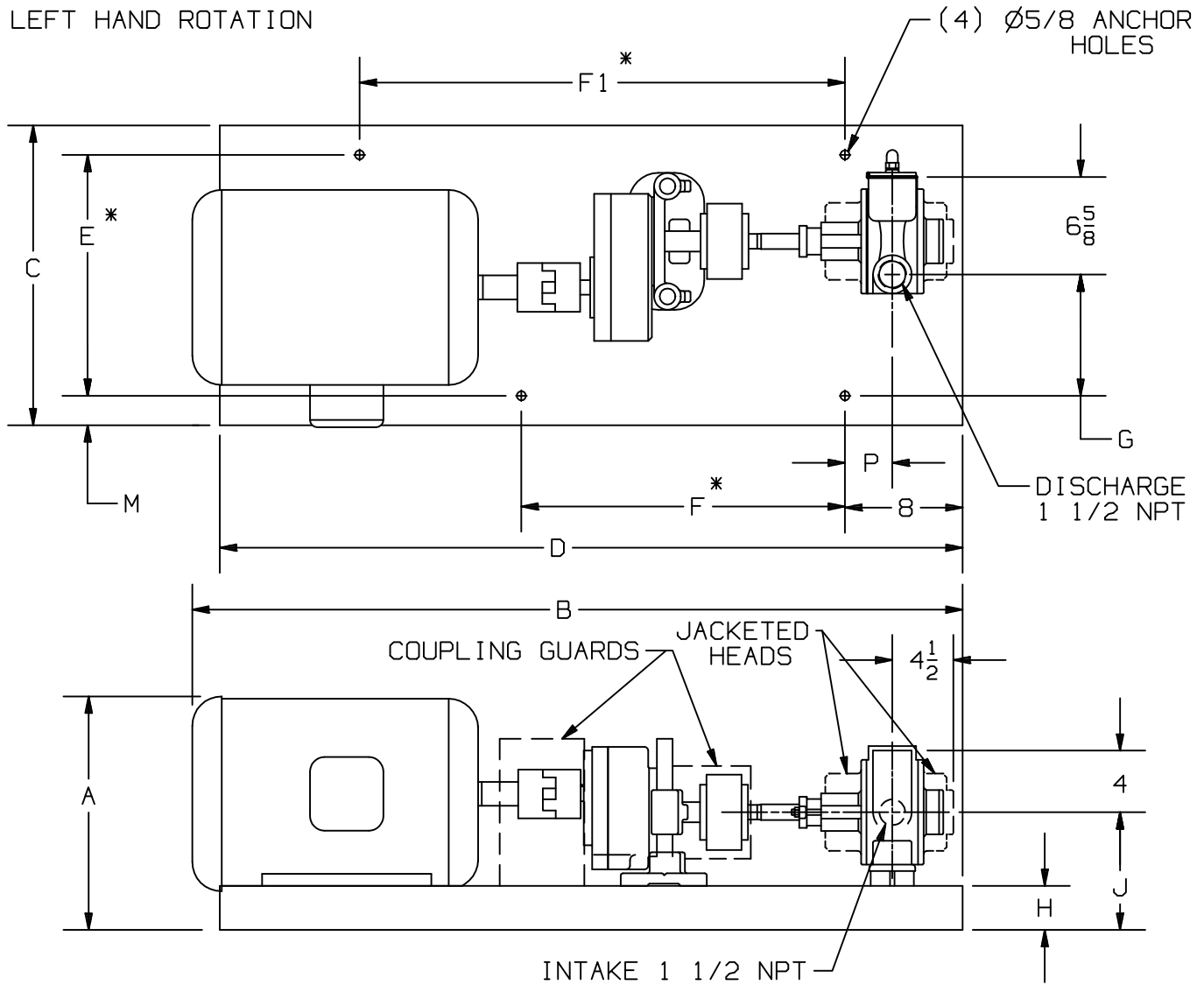

* TOLERANCE ±1/8
 TOLERANCE ON OTHER DIMENSIONS ±1/4
 "A" DIMENSION LESS EYEBOLT

MOTOR			BASE NO.	DIMENSIONS												
FRAME SIZE				A	B	C	D	E	F	F ₁	G	H	J	M	P	
143T			901795	9 3/4	45 3/8	17 1/4	44	14	15	26	7 1/8	2 1/4	7 1/4	1 5/8	4 1/8	
145T			901795	9 3/4	45 3/8	17 1/4	44	14	15	26	7 1/8	2 1/4	7 1/4	1 5/8	4 1/8	
182T			901795	11 7/8	45 3/8	17 1/4	44	14	15	26	7 1/8	2 1/4	7 1/4	1 5/8	4 1/8	
184T			901795	11 7/8	46 1/8	17 1/4	44	14	15	26	7 1/8	2 1/4	7 1/4	1 5/8	4 1/8	
213T			901794	14 1/8	51 1/4	20 3/8	50 1/2	16 3/8	22	33	8 1/4	3	8	2	3 1/4	
215T			901794	14 1/8	51 1/4	20 3/8	50 1/2	16 3/8	22	33	8 1/4	3	8	2	3 1/4	
254T			901794	16 3/8	53 1/8	20 3/8	50 1/2	16 3/8	22	33	8 1/4	3	8	2	3 1/4	
256T			901794	16 3/8	54 7/8	20 3/8	50 1/2	16 3/8	22	33	8 1/4	3	8	2	3 1/4	